

CFR+ / CFRE+

Horizontal heat recovery unit with aluminum counterflow static exchanger



Technical and construction characteristics

The air renewal units of the CFR+ and CFRE+ series are characterized by the adoption of a special aluminum air-air exchanger with counter-current flows.

This allows us to avoid, or in any case significantly reduce, the use of replacement air post-treatment systems, with what this entails in terms of energy and plant engineering.

The units of the CFR+ and CFRE+ series, intended for false ceiling or similar applications, allow for large system configurations and have standard fans which can be replaced, alternatively, by the corresponding EC technology ones (CFRE+ series).

They are equipped as standard with compact filters with F7 efficiency on the renewal flow and M5 on the expulsion flow (F7 in optional expulsion) and integrate optimally with traditional environmental heating/air conditioning systems, whether they are located in series or in parallel.

The CFR+ series consists of n. 6 models, while the CFRE+ series consists of n. 8 models, all exclusively in the horizontal version, to cover an air exchange requirement from a minimum of 400 m³/h up to a maximum of 5000 m³/h.

All models can be supplied in combination with an air ionization system called BIOXIGEN®.

This system, unique in its kind, has the purpose of sanitizing and deodorizing the air and surfaces of the machine, ducts and confined spaces.

The general characteristics are:

- Double inlet centrifugal electric fans with technology AC on CFR+ models;
- Double inlet centrifugal electric fans with technology EC on CFRE+ models;
- Integrated thermal by-pass device;
- 23 mm thick sandwich panel structure in sheet metal galvanized inside and pre-painted outside, with insulation thermoacoustic in injected polyurethane with density 45 kg/m³;
- Filtration sections made up of compact cell filters polypropylene with low pressure drop, laterally extractable, in ISO 16890 efficiency class ePM1 55% in the renewal flow and ePM10 55% in the expulsion flow;
- Integrated dirty filter warning pressure switch;
- Condensate collection tray in galvanized sheet metal with connection lower drain which guarantees total drainage.

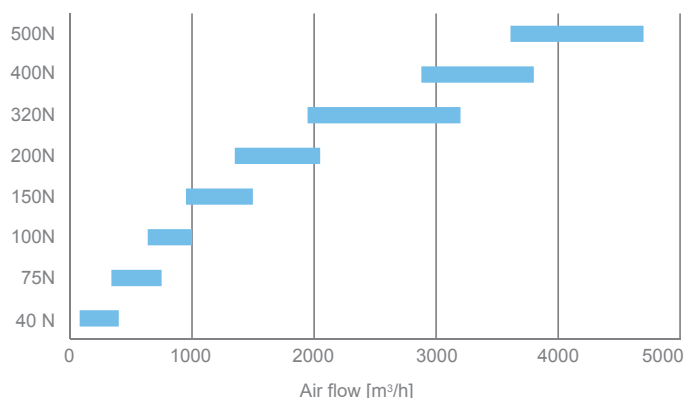

ERP 2018 COMPLIANT



OPTIONAL BIOXIGEN SYSTEM



DUCTED UNIT



AIR FILTRATION



AIR RENEWAL



ENERGY SAVING



CONSTANT AIR FLOW



EC (CFRE+) FANS



ENERGY RECOVERY













EASY INSTALLATION

Model	Nominal air flow m ³ /h	Winter efficiency %	Summer efficiency%	Code	€
CFR+ 40N	400	83,6	75,5	75800301	3.470,00
CFR+ 75N	750	82,9	75,9	75800302	4.820,00
CFR+ 100N	1000	81,6	74,5	75800303	5.070,00
CFR+ 150N	1500	83,3	75,1	75800304	5.580,00
CFR+ 200N	2050	83,7	75,6	75800305	6.820,00
CFR+ 320N	3200	86,8	78,0	75800306	7.340,00
CFRE+ 40N	400	83,6	75,5	75801301	4.630,00
CFRE+ 75N	750	82,9	75,9	75801302	6.370,00
CFRE+ 100N	1000	81,6	74,5	75801303	6.650,00
CFRE+ 150N	1500	83,3	75,1	75801304	7.420,00
CFRE+ 200N	2050	83,7	75,6	75801305	8.530,00
CFRE+ 320N	3200	86,8	78,0	75801306	9.400,00
CFRE+ 400N	3800	84,1	75,0	75801307	10.800,00
CFRE+ 500N	4700	84,2	75,1	75801308	11.750,00

CFR+ / CFRE+

Horizontal heat recovery unit with aluminum counterflow static exchanger









Accessories CFR+ / CFRE+

		Code	€
	Automatic free cooling bypass kit for opening the bypass by reading the air conditions	mod. 40N - 150N	75800361 410,00
		mod. 200N - 500N	75810361 410,00
	PRE and POST heating electric resistance installed on the machine complete with safety thermostat and relay	mod. PRE 40N (1,5 kW M)	75810321 692,00
		mod. PRE 75N - 100N (3 kW M)	75810322 692,00
		mod. PRE 150N - 200N (6 kW T)	75810323 738,00
		mod. PRE 320N (12 kW T)	75810326 966,00
		mod. PRE 400N (12 kW T)	75810327 1.090,00
		mod. PRE 500N (18 kW T)	75810328 1.208,00
		mod. POST 40N (1,5 kW M)	75800321 692,00
		mod. POST 75N - 100N (3 kW M)	75800322 692,00
		mod. POST 150N - 200N (6 kW T)	75800323 738,00
		mod. POST 320N (12 kW T)	75800326 966,00
		mod. POST 400N (12 kW T)	75800327 1.090,00
mod. POST 500N (18 kW T)	75800328 1.208,00		
	Internal 2-row water post-heating coil with 3/4" connections fixed directly inside the recovery unit	mod. 40N (3,3 kW)	75800331 446,00
		mod. 75N - 100N (7,8 kW)	75800332 546,00
		mod. 150N (10,7 kW)	75800334 686,00
		mod. 200N (14,8 kW)	75800335 732,00
		mod. 320N (20,5 kW)	75800336 792,00
		mod. 400N (23,7 kW)	75800337 956,00
		mod. 500N (30,4 kW)	75800338 1.048,00
	2-way valve kit with ON-OFF servomotor for internal post-heating coil	mod. 40N - 400N	75800340 298,00
		mod. 500N	75800360 392,00
	3-way valve kit with modulating servomotor for internal post-heating coil	mod. 40N - 400N	75801397 522,00
		mod. 500N	75801399 528,00
	Section with water coil 3 rows for post-heating and cooling positioned outside the machine in front of the mouth intake complete with stainless steel condensate tray	mod. 40N (5,1 kW)	75800341 884,00
		mod. 75N - 100N (11,8 kW)	75800342 1.160,00
		mod. 150N (18,6 kW)	75800344 1.288,00
		mod. 200N (23,9 kW)	75800345 1.476,00
		mod. 320N (35,5 kW)	75800346 1.680,00
		mod. 400N (41,6 kW)	75800347 1.904,00
		mod. 500N (49,2 kW)	75800348 2.184,00
	2-way valve kit with ON-OFF servomotor for external post-heating and cooling coil	mod. 40N - 200N	75800479 298,00
		mod. 320N - 400N	75800481 392,00
		mod. 500N	75800482 410,00
	3-way valve kit with ON-OFF servomotor for external post-heating and cooling coil	mod. 40N - 200N	75801388 404,00
		mod. 320N - 400N	75801389 410,00
	3-way valve kit with modulating servomotor for external post-heating and cooling coil	mod. 40N - 200N	75801390 522,00
		mod. 320N - 400N	75801398 528,00
		mod. 500N	75801400 628,00
	Pressure switch for signaling filter clogging	75800617	192,00
	Anti-freeze thermostat on board the machine to avoid the formation of frost to be purchased in combination with the electric pre-heating resistance	75800362	206,00

CFR+ / CFRE+

Horizontal heat recovery unit with aluminum counterflow static exchanger











Accessories CFR+ / CFRE+

		Code	€
 <p>Section with 3 dampers, system for mixing external air with exhaust air active in winter mode</p>	mod. 40N (800x370 mm)	75800333	932,00
	mod. 75N - 100N (990x470 mm)	75800343	1.042,00
	mod. 150N (1000x540 mm)	75800357	1.446,00
	mod. 200N (1400x540 mm)	75800358	1.640,00
	mod. 320N (1400x670 mm)	75800365	1.704,00
	mod. 400N (1400x670 mm)	75801365	1.732,00
	mod. 500N (1700x680 mm)	75800366	1.944,00
 <p>Servomotor kit for section of 3 dampers 230V 2/3 point control</p>	mod. 40N - 500N	75800483	996,00
	mod. 40N - 500N	75800484	1.434,00
 <p>Servomotor kit for section of 3 dampers 230V ON-OFF spring return control</p>	mod. 40N (Ø 200)	75800390	342,00
	mod. 75N - 100N (Ø 315)	75800372	298,00
	mod. 150N (Ø 355)	75800374	346,00
	mod. 200N (Ø 355)	75800375	358,00
	mod. 320N (Ø 400)	75800376	370,00
	mod. 400 N - 500N (Ø 450)	75800377	422,00
	 <p>Circular connections kit in galvanized sheet metal to connect the unit to the circular section aeraulic ducts on both the pressing and suction sides (kit consisting of n. 4 connections)</p>	mod. 40N	75801391
mod. 75N - 100N		75801392	890,00
mod. 150N		75801393	816,00
mod. 200N		75801394	860,00
mod. 320N - 400N		75801395	952,00
mod. 500N		75801396	1.000,00
 <p>Outdoor installation kit including: - Weatherproof roof - Rain cover - Basement - Outdoor electrical box</p>	mod. 40N	75800471	136,00
	mod. 75N - 100N	75800472	200,00
	mod. 150N	75800473	262,00
	mod. 200N	75800474	328,00
	mod. 320N	75800475	392,00
	mod. 400N - 500N	75800476	392,00
 <p>External headphone kit for the inlet of the fresh air and the expulsion of exhausted air without the need for ducting</p>	mod. 40N (300x300 mm)	75800381	532,00
	mod. 75N - 100N (300x450 mm)	75800382	978,00
	mod. 150N (600x450 mm)	75800384	1.066,00
	mod. 200N (600x600 mm)	75800385	1.182,00
	mod. 320N (600x750 mm)	75800386	1.260,00
	mod. 400N - 500N (750x750 mm)	75800387	1.500,00
 <p>Duct silencer composed of rectangular section baffles made of galvanized steel sheet filled with glass wool covered with a compact fabric</p>	mod. 40N	75800477	94,00
	mod. 75N - 100N	75800478	158,00
	mod. 150N	75800380	176,00
	mod. 200N	75800371	212,00
	mod. 320 N - 400N	75800368	258,00
	mod. 500N	75800453	276,00
 <p>High efficiency filters ISO 16890 (F7 EN 779) in polypropylene to be inserted on the machine in place of the standard filter supplied as standard</p>	mod. 40N	75800391	468,00
	mod. 75N - 100N	75800392	726,00
	mod. 150N	75800394	756,00
	mod. 200N	75800395	844,00
	mod. 320N	75800396	1.100,00
	mod. 400N - 500N	75800397	1.270,00
 <p>Module with Bioxygen® duct sanitization system, to be positioned in correspondence with the external air intake</p>			

CFR+ / CFRE+

Horizontal heat recovery unit with aluminum counterflow static exchanger

Accessories CFR+ / CFRE+

		Code	€
	Regulation damper consisting of a galvanized sheet metal frame with adjustable fins	mod. 40N	75800351 176,00
		mod. 75N - 100N	75800352 262,00
		mod. 150N	75800353 272,00
		mod. 200N	75800354 304,00
		mod. 320N	75800355 316,00
		mod. 400N - 500N	75800356 344,00
	Servomotor for regulation damper 230V 2/3 point control	mod. 40N - 500N	75801366 334,00
	Servomotor for 230V regulation dampers ON-OFF spring return control	mod. 40N - 500N	75800370 556,00
	Electronic wall panel for controlling the PCUS unit	75800897	310,00
	Electronic wall panel for control of the unit complete with Modbus port for PCUSM remote management	75810021	392,00
	Electronic wall panel for the control of the unit and for the management of the PCUS-V3M 3-way valve kit	75800363	458,00
	Electronic wall panel for controlling the unit complete with Modbus port for remote management and for managing the PCUSM-V3M 3-way valve kit	75800369	540,00
	CO2 probe for ventilation control based on the quality of the ambient air	mod. duct	75801382 1.072,00
		mod. wall	75800867 1.142,00
	Humidity probe for ventilation control based on the humidity detected in the environment	mod. duct	75800869 540,00
		mod. wall	75800868 310,00
	Duct probes for electronic measurement of the air intake and exhaust temperature	75810020	82,00

Orientations available CFR+ / CFRE+

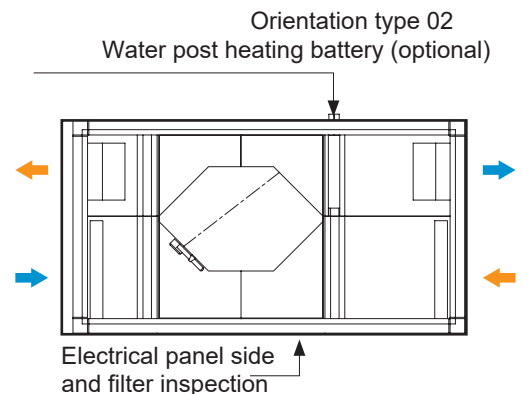
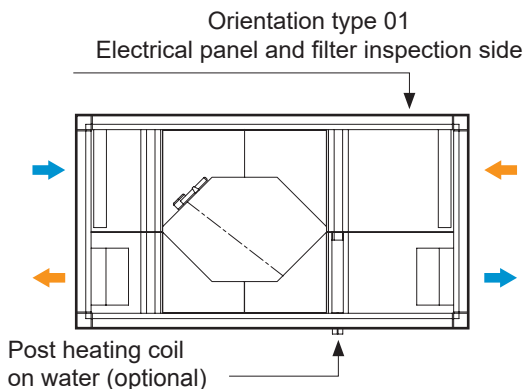

Legend:  Expelled air  Renewal air - The orientations depicted are relative to the machines seen from above

CFR+ / CFRE+

Horizontal heat recovery unit with aluminum counterflow static exchanger

Dimensions CFR+ / CFRE+

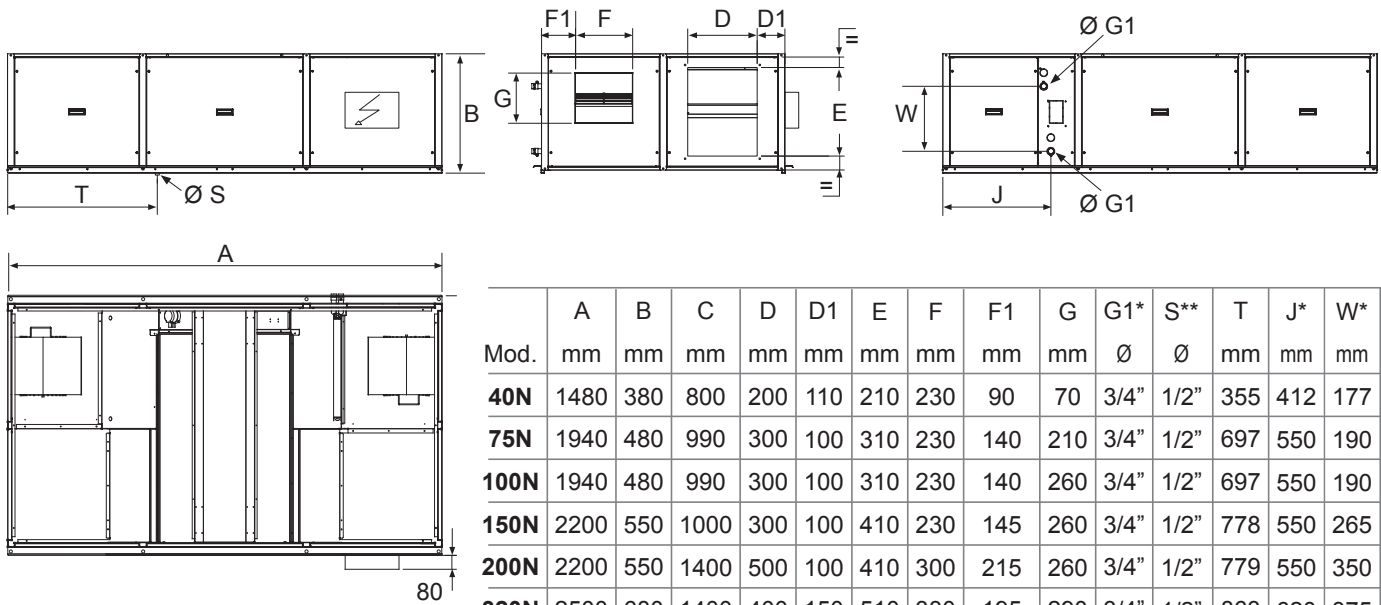

Mod.	A	B	C	D	D1	E	F	F1	G	G1*	S**	T	J*	W*	Weight
	mm	mm	mm	mm	mm	mm	mm	mm	mm	Ø	Ø	mm	mm	mm	Kg
40N	1480	380	800	200	110	210	230	90	70	3/4"	1/2"	355	412	177	90
75N	1940	480	990	300	100	310	230	140	210	3/4"	1/2"	697	550	190	140
100N	1940	480	990	300	100	310	230	140	260	3/4"	1/2"	697	550	190	150
150N	2200	550	1000	300	100	410	230	145	260	3/4"	1/2"	778	550	265	170
200N	2200	550	1400	500	100	410	300	215	260	3/4"	1/2"	779	550	350	200
320N	2500	680	1400	400	150	510	330	195	290	3/4"	1/2"	863	620	375	230
400N	2500	680	1400	500	100	510	405	157	405	1"	1/2"	863	620	375	260
500N	2500	680	1700	500	185	510	405	232	405	1"	1/2"	863	620	375	300

(*) Optional post-heating water coil connections
 (**) Condensate drain

Technical data table section with external hot/cold water coil, dimensions and weights

Module to be positioned outside the machine in front of the inlet, complete with stainless steel condensate collection tray

Model	U.M.	40N	75N	100N	150N	200N	320N	400N	500N
Geometry		2522	2522	2522	2522	2522	2522	2522	2522
Pipes by rank	n.	13	16	16	24	26	28	32	32
Ranks	n.	3	3	3	3	3	3	3	3
Pitch fins	mm	2,1	2,1	2,1	2,1	2,1	2,1	2,1	2,1
Thermal power*	kW	5,1	9,5	11,8	18,6	23,9	35,5	41,6	49,2
Water outlet temperature	°C	52,3	52,1	49,5	48,9	49,0	47,9	47,8	45,6
Heating water flow rate	m³/h	0,4	0,8	1,0	1,6	2,1	3,1	3,7	4,3
Water pressure drops	kPa	3	5	7	7	19	46	11	14
Air pressure drops	Pa	17	19	30	34	37	47	43	64
Cooling power**	kW	2,6	5,1	6,2	9,8	13,3	18,7	22,1	25,6
Sensible cooling capacity	kW	1,4	2,7	3,3	5,2	7,0	9,9	11,7	13,7
Air outlet temperature	°C	16,7	16,3	17,1	17,3	16,8	17,8	17,5	15,3
Cooling water flow rate	m³/h	0,4	0,9	1,1	1,7	2,3	3,2	3,8	4,4
Water pressure drops	kPa	4,2	6,7	9,5	10,2	28,6	20,6	15,0	19,5
Air pressure drops	Pa	25	26	45	50	54	65	64	70

(*) Values referred to: Air T_{ing} 15 °C - Water in/out 70/60 °C nominal air flow
 (**) Values referred to: Air T_{ing} 27 °C RH 65% - Water in/out 7/12 °C nominal air flow

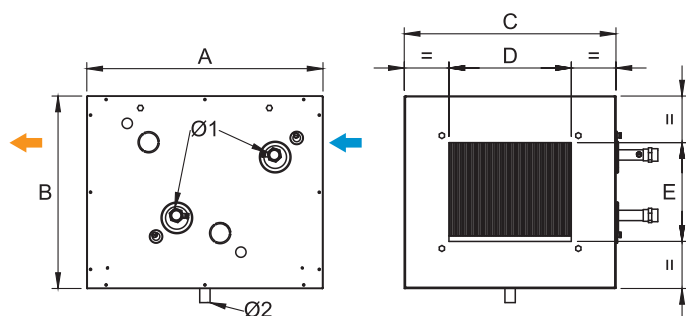

Model	A	B	C	D	E	Ø1	Ø2	Weight Kg
40	430	370	420	200	210	3/4"	22	14
75/100	500	470	510	300	310	3/4"	22	17
150	620	540	520	300	410	3/4"	22	21
200	700	540	670	500	410	3/4"	22	26
320	700	670	720	400	510	3/4"	22	31
400	700	680	720	500	510	1"	22	42
500	700	680	870	500	510	1"	22	42

Values in mm

CFR+ / CFRE+

Horizontal heat recovery unit with aluminum counterflow static exchanger

Technical data table CFR+ / CFRE+ 40÷150

Model	U.M.	CFR+ 40	CFRE+ 40	CFR+ 75	CFRE+ 75	CFR+ 100	CFRE+ 100	CFR+ 150
Nominal air flow	m ³ /h	400		750		1000		1500
Nominal useful static pressure	Pa	160		120		180		160
Max useful static pressure	Pa	160	340	120	210	180	520	160
Electrical supply		230V/1/50Hz						
Total max absorbed current	kW	0,35	0,56	0,68	0,56	1,41	2,12	1,41
Total max absorbed current	A	1,5	2,4	2,9	2,4	6,0	9,0	6,0

OPERATING LIMITS

External temperature and humidity limit conditions		(-5 °C) ÷ (+45 °C) / (5%) ÷ (95%)						
External temperature humidity limit conditions with 3 dampers section		(-15 °C) ÷ (+45 °C) / (5%) ÷ (95%)						
Internal temperature limit humidity conditions		(+10 °C) ÷ (+35 °C) / (10%) ÷ (90%)						

FANS

Engine type		AC	EC	AC	EC	AC	EC	AC
Speed number (1)		3	Multiple	3	Multiple	3	Multiple	3
Ventilation control (1)		MAN	0 -10V VSD	MAN	0 -10V VSD	MAN	0 -10V VSD	MAN
Total nominal absorbed power	kW	0,17	0,16	0,38	0,30	0,60	0,57	0,80
Total nominal absorbed current	A	0,7	0,7	1,6	1,3	2,5	2,4	3,4
Static efficiency of the fans	%	N.A.	32,7	38,6	32,7	38,6	53,2	38,64

HEAT RECOVERY

Winter thermal efficiency (2)	%	83,6		82,9		81,6		83,3
Recovered thermal power (2)	kW	2,76		5,13		6,73		10,30
Supply air temperature (2)	°C	15,9		15,7		15,4		15,8
Summer thermal efficiency (3)	%	75,5		75,9		74,5		75,1
Recovered cooling capacity (3)	kW	0,61		1,15		1,50		2,20
Supply air temperature (3)	°C	27,5		27,4		27,5		27,5
Dry thermal efficiency (4)	%	75,9		76,4		75,0		75,6

Specific data table ECODESIGN CFR+ / CFRE+ 40÷150

	U.M.	40	40E	75	75E	100	100E	150
Declared typology		NRVU - BVU						
Internal specific ventilation power - SFP int (4)	W(m ³ /s)	740	705	934	742	1105	1059	1102
Internal specific maximum power of ventilation components (SFPint_limite)	W(m ³ /s)	1170	1170	1171	1171	1118	1118	1116
Front speed at nominal capacity	m/s	0,93	0,93	1,36	1,36	1,81	1,81	2,00
Pressure loss of internal ventilation components (Δps, int)	Pa	140	140	119	119	179	179	202
Maximum external leakage of the casing	%	< 3,5	< 3,5	< 3,5	< 3,5	< 3,5	< 3,5	< 3,5
Maximum internal leakage or residual flow	%	< 4	< 4	< 4	< 4	< 4	< 4	< 4
Calculated annual energy consumption of the filters (8760 h of operation)	kWh/a	613	487	1228	1448	2320	1684	3945
Sound power level radiated by the enclosure (5)	dB(A)	50	49	53	52	53	51	56

(1) Multiple = Multispeedà > 3

Man = Manual from selector or keyboard;

0-10V = From potentiometer or keyboard;

VSD = Constant flow or modulated by air quality/humidity sensor

(2) Outdoor air -5 °C 80% RH; ambient air 20 °C 50% RH

(3) Outdoor air 32 °C 50% RH; ambient air 26 °C 50% RH

(4) According to EU regulation 1253/2014: at nominal pressure; temperature and humidity conditions referred to EN 308

(5) Sound power level according to EU regulation 1253/2014, at nominal pressure, temperature and humidity conditions referred to EN 308

CFR+ / CFRE+

Horizontal heat recovery unit with aluminum counterflow static exchanger

Technical data table CFR+ CFRE+ / 150÷500

Model	U.M.	CFRE+ 150	CFR+ 200	CFRE+ 200	CFR+ 320	CFRE+ 320	CFRE+ 400	CFRE+ 500
Nominal air flow	m ³ /h	1500	2050	2050	3200	3200	3800	4700
Nominal useful static pressure	Pa	160	120	120	180	180	200	200
Max useful static pressure	Pa	500	120	540	180	375	330	200
Electrical supply		230V/1/50Hz						
Total max absorbed current	kW	2,12	1,41	2,12	3,29	2,35	2,07	2,07
Total max absorbed current	A	9,0	6,0	9,0	14,0	10,0	8,8	8,8

OPERATING LIMITS

External temperature and humidity limit conditions		(-5 °C) ÷ (+45 °C) / (5%) ÷ (95%)						
External temperature humidity limit conditions with 3 dampers section		(-15 °C) ÷ (+45 °C) / (5%) ÷ (95%)						
Internal temperature limit humidity conditions		(+10 °C) ÷ (+35 °C) / (10%) ÷ (90%)						

FANS

Engine type		EC	AC	EC	AC	EC	EC	EC
Speed number (1)		Multiple	3	Multiple	3	Multiple	Multiple	Multiple
Ventilation control (1)		0 -10V VSD	MAN	0 -10V VSD	MAN	0 -10V VSD	0 -10V VSD	0 -10V VSD
Total nominal absorbed power	kW	0,76	1,00	0,84	1,79	1,77	1,78	2,19
Total nominal absorbed current	A	3,2	4,3	3,6	7,6	7,5	7,6	9,3
Static efficiency of the fans	%	53,2	40,4	55,9	43,4	59,8	66,9	66,9

HEAT RECOVERY

Winter thermal efficiency (2)	%	83,3	83,7	83,7	86,8	86,8	84,1	84,2
Recovered thermal power (2)	kW	10,30	14,14	14,14	22,90	22,90	26,34	32,62
Supply air temperature (2)	°C	15,8	15,9	15,9	16,7	16,7	16,0	16,1
Summer thermal efficiency (3)	%	75,1	75,6	75,6	78,0	78,0	75,0	75,1
Recovered cooling capacity (3)	kW	2,27	3,12	3,12	5,02	5,02	5,73	7,10
Supply air temperature (3)	°C	27,5	27,5	27,5	27,3	27,3	27,5	27,5
Dry thermal efficiency (4)	%	75,6	75,0	75,0	75,3	75,3	75,5	75,6

Specific data table ECODESIGN CFR+ / CFRE+ 150÷500

	U.M.	150E	200	200E	320	320E	400E	500E
Declared typology		NRVU - BVU						
Internal specific ventilation power - SFP int (4)	W(m ³ /s)	1048	1078	898	1054	1040	949	935
Maximum specific internal power of the ventilation components (SFPint_limite)	W(m ³ /s)	1116	1105	1105	1066	1066	1017	982
Front speed at nominal capacity	m/s	2,00	1,83	1,83	2,06	2,06	2,44	2,42
Perdita di pressione dei componenti interni della ventilazione (Δps, int)	Pa	202	177	177	194	194	252	248
Maximum external leakage of the casing	%	< 3,5	< 3,5	< 3,5	< 3,5	< 3,5	< 3,5	< 3,5
Maximum internal leakage or residual flow	%	< 4	< 4	< 4	< 4	< 4	< 4	< 4
Calculated annual energy consumption of the filters (8760 h of operation)	kWh/a	2862	4601	3325	5562	4036	5456	6649
Sound power level radiated by the enclosure (5)	dB(A)	61	64	59	68	64	66	68

(1) Multiple = Multispeed > 3

Man = Manually via selector or keyboard;

0-10V = From potentiometer or keyboard;

VSD = Constant flow or modulated by air quality/humidity sensor

(2) External air -5 °C 80% RH; ambient air 20 °C 50% RH

(3) Outdoor air 32°C 50% RH; ambient air 26 °C 50% RH

(4) According to EU regulation 1253/2014: at nominal pressure; temperature and humidity conditions referred to EN 308

(5) Sound power level at nominal operating conditions