

MHD ECM

Reduced thickness ductable air treatment terminal units

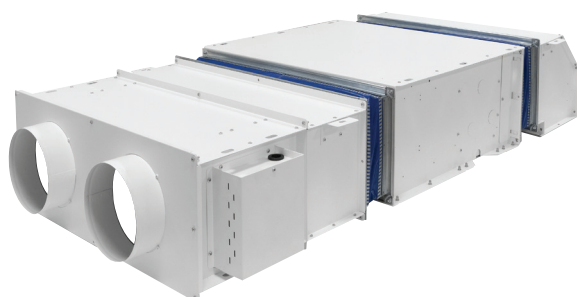

Technical and construction characteristics

The MHD ECM reduced thickness ducted air handling units are available in 7 power versions.

MHD ECM units are particularly suitable for use in small and medium centralized air conditioning systems with air distribution via a duct network.

The reduced height thickness makes the units compact, in order to better adapt to false ceiling installations, optimizing the available spaces in the best possible way.

Great attention was also paid to reducing and simplifying maintenance times, allowing the filter to be removed from both the sides and the bottom.

Construction features

Single panel load-bearing structure:

made of Z200 hot-dip galvanized sheet metal, 1 mm and 1.5 mm thick (size 6-7) insulated with a closed-cell class B-s2, d0 thermo-acoustic mat, 6 mm thick.

Condensate collection tray:

made of Z200 hot-dip galvanized sheet metal, 1 mm thick, externally insulated with a class B-s2, d0 closed cell thermo-acoustic mat, 6 mm thick.

Air filter:

supplied as standard and integrated into the unit, easily removable from the side or bottom, regenerable and made of synthetic filter fabric enclosed by a galvanized steel frame and efficiency class G3*/EU3** with a thickness of 12 mm.

Electric fan unit:

equipped with innovative Brushless ECM motors which guarantee precise and modular control of the air flow, limiting the energy input to the actual workload required, without unnecessary waste.

Heat exchange coil:

Copper tube coils with continuously packed aluminum fins locked onto the tubes by mechanical expansion.

Copper manifolds equipped with male gas threaded connections and easily accessible air vent valves.

Hydraulic connections positioned on the left (looking at the air delivery of the unit), on request they can be supplied on the right.

Check:

electronic thermostat with LCD display

Model	Cooling power kW	Heating power kW	Air flow m ³ /h	Code	€
MHD ECM1	2,78	2,90	469	53000000	1.574,00
MHD ECM2	5,92	6,41	1007	53000001	1.956,00
MHD ECM3	7,82	8,31	1267	53000002	2.612,00
MHD ECM4	11,27	12,24	1946	53000003	4.532,00
MHD ECM5	15,13	16,84	2805	53000004	4.937,00
MHD ECM6	22,56	25,54	4357	53000005	6.293,00
MHD ECM7	27,85	31,82	5668	53000006	8.744,00

Reference values:

- Cooling capacity calculated at speed 3 (average fan speed)











- Heating capacity calculated at speed 3 (average fan speed)

- Air flow calculated at speed 3 (average fan speed)

MHD ECM

Reduced thickness ductable air treatment terminal units

MHD ECM Accessories Compatibility

	1	2	3	4	5	6	7	8	9	10	11	12
 MHD ECM UNIT		✓	✓	✓	✓	✓	✓	✓	✓	✗	✗	✗
 PAM Straight plenum intake/delivery	✓		✓	✓	✓	✓	✓	✓	✓	✓	✓	✓
 RAM Plenum 90° suction/delivery	✓	✓		✓	✓	✓	✓	✓	✓	✓	✓	✓
 GAM Anti-vibration joint for suction/delivery	✓	✓	✓		✓	✓	✓	✓	✓	✓	●	●
 SRE Electric resistance heating section	✓	✓	✓	✓		✗	✓		✗	✓	●	✗
 SRA Post heating/cooling section with water coil	✓	✓	✓	✓	✓		✓	✗	✗	✓	●	✗
 USG Humidification section with droplet separator	✓	✓	✓	✓	✓	✓		✗	✗	✓	●	✓
 SSP Section with air intake	✓	✓	✓	✓	✗	✗	✗		✗	✗	✓	●
 ALLUMINIUM SHUTTER	✓	✓	✓	✓	✗	✗	✗	✗		✗	✓	●
 BAM Delivery nozzle with circular connections	✗	✓	✓	✓	●	●	●	✓	✗	✗	✓	●
 RECOVERY GRID	✗	✓	✓	✓	●	✗	✗	✓	✓	●	✗	
 DELIVERY GRID	✗	✓	✓	✓	●	✗	✓	✓	✗	✗	✗	

LEGEND

✓ Compatible

✗ Not compatible

● Installation of PAM, RAM or interposed channel is mandatory

MHD ECM

Reduced thickness ductable air treatment terminal units

MHD ECM Accessories Compatibility

ASPIRATION

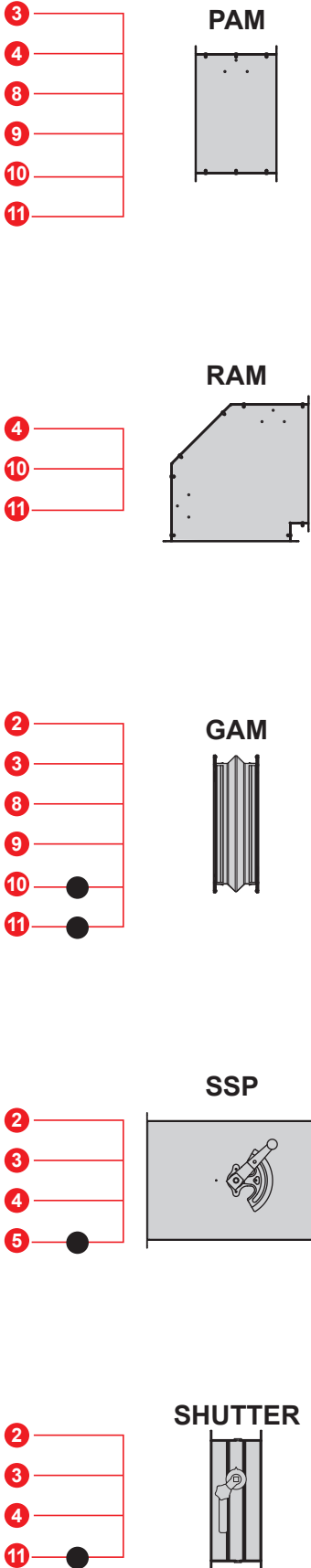

MHD ECM UNIT

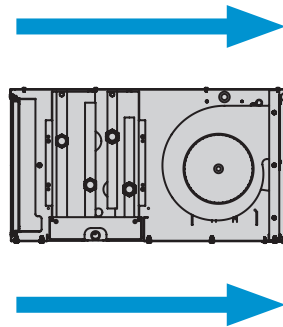

DELIVERY

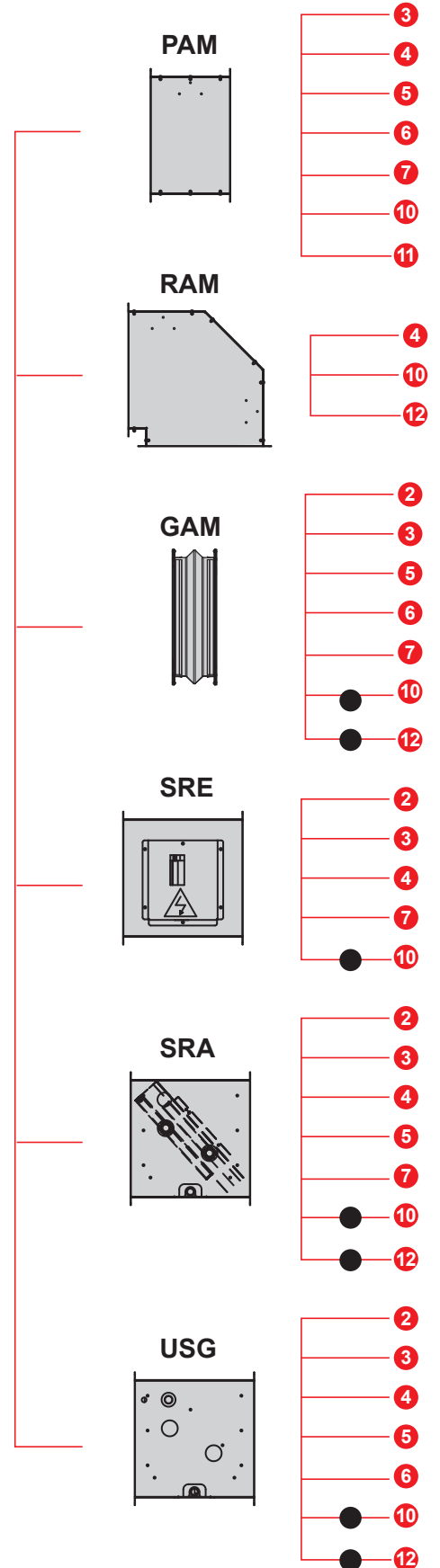

● Installation of PAM, RAM or interposed channel is mandatory

MHD ECM

Reduced thickness ductable air treatment terminal units

MHD ECM accessories compatibility example of combination

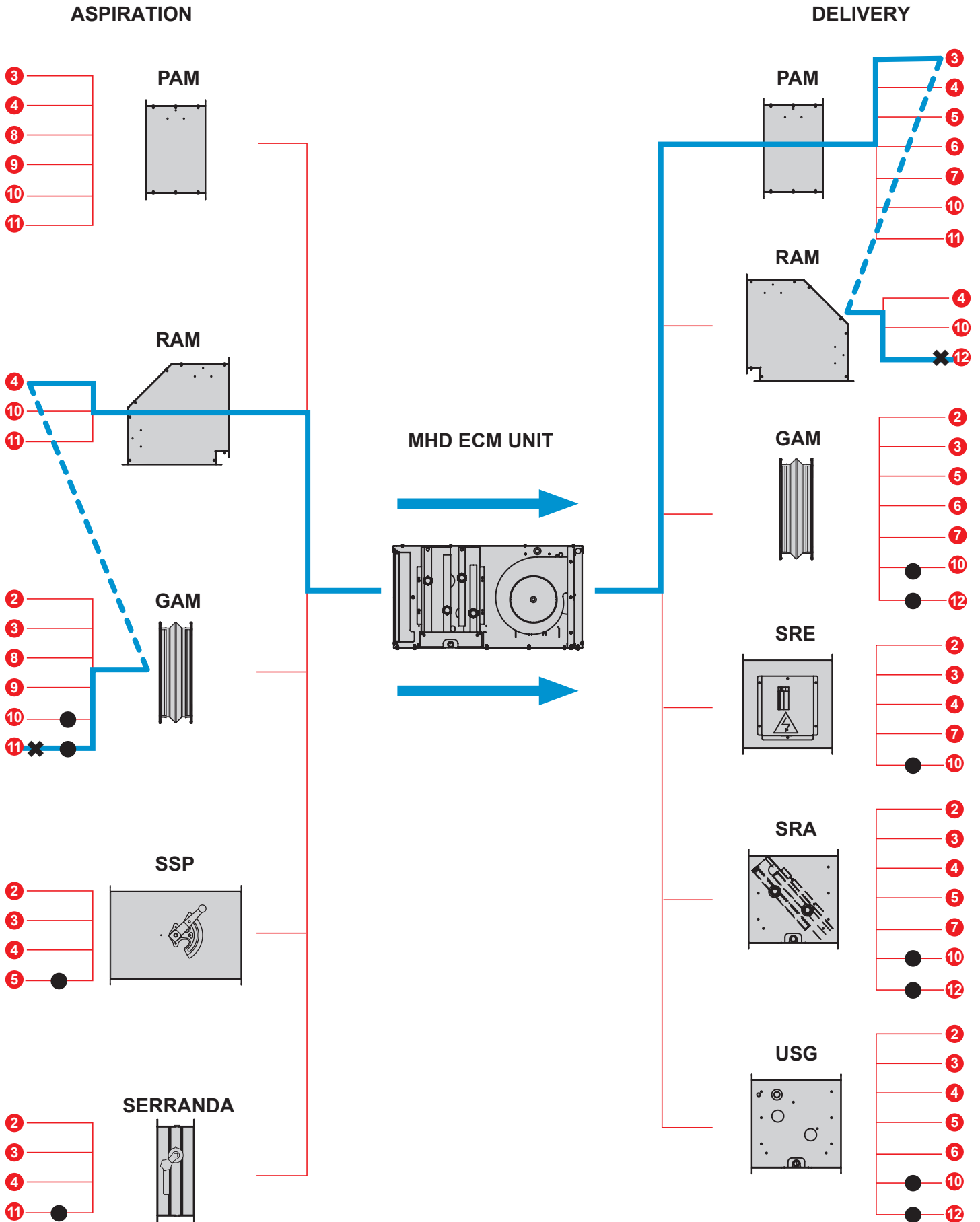

● Installation of PAM, RAM or interposed channel is mandatory

MHD ECM

Reduced thickness ductable air treatment terminal units

Accessories MHD ECM

Code

€

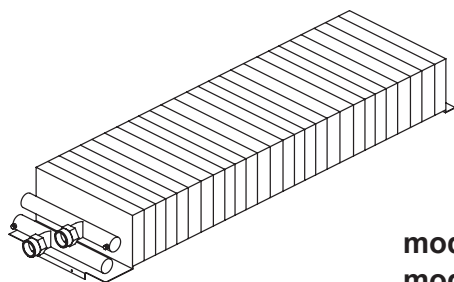

6-rank battery

Technical data:

PC (W) 7-12 °C (cooling)

PH (W) 50 °C (heating)

Calculated at 6 speed

mod. ECM 1	6R 5NC	PC 3650 W	PH 4150 W	53000014	617,00
mod. ECM 2	6R 7NC	PC 7750 W	PH 9090 W	53000015	643,00
mod. ECM 3	6R 11NC	PC 11870 W	PH 14090 W	53000016	805,00
mod. ECM 4	6R 13NC	PC 15600 W	PH 18490 W	53000017	851,00
mod. ECM 5	6R 15NC	PC 20100 W	PH 24180 W	53000018	942,00
mod. ECM 6	6R 22NC	PC 32970 W	PH 40820 W	53000019	1.217,00
mod. ECM 7	6R 24NC	PC 36270 W	PH 45130 W	53000020	1.248,00

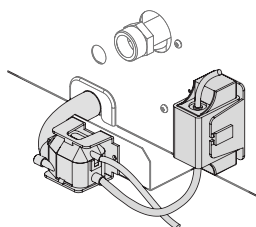

Condensate drain pump kit

mod. ECM 1	53000021	350,00
mod. ECM 2	53000022	350,00
mod. ECM 3	53000023	354,00
mod. ECM 4	53000024	354,00
mod. ECM 5	53000025	354,00

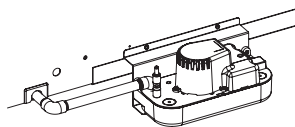

Condensate drain pump kit

mod. ECM 6	53000027	552,00
mod. ECM 7	53000028	552,00

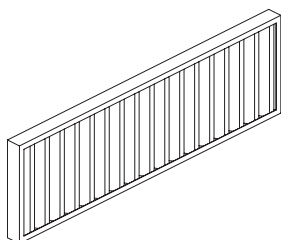

Air filter
filtration level G4
Thickness 48 mm

mod. ECM 1	53000029	48,00
mod. ECM 2	53000030	64,00
mod. ECM 3	53000031	65,00
mod. ECM 4	53000032	68,00
mod. ECM 5	53000033	106,00
mod. ECM 6	53000034	242,00
mod. ECM 7	53000035	271,00

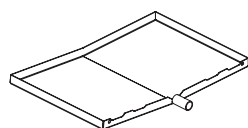

Auxiliary
condensate
collection tray

mod. ECM 1-3	53000029	48,00
mod. ECM 4-7	53000030	64,00

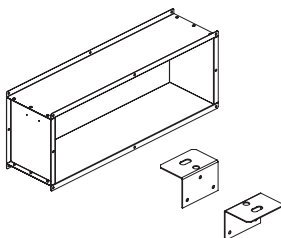

Straight intake plenum
ceiling fixing kit included

mod. ECM 1	53000038	133,00
mod. ECM 2	53000039	143,00
mod. ECM 3	53000040	150,00
mod. ECM 4	53000041	156,00
mod. ECM 5	53000042	158,00
mod. ECM 6	53000043	188,00
mod. ECM 7	53000044	188,00

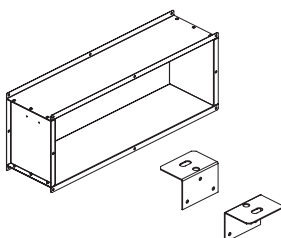

Straight delivery plenum
ceiling fixing kit included

mod. ECM 1	53000045	179,00
mod. ECM 2	53000046	206,00
mod. ECM 3	53000047	216,00
mod. ECM 4	53000048	230,00
mod. ECM 5	53000049	233,00
mod. ECM 6	53000050	246,00
mod. ECM 7	53000051	274,00

MHD ECM

Reduced thickness ductable air treatment terminal units

Accessories MHD ECM

Code

€

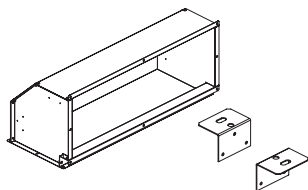

90° suction plenum, ceiling fixing kit included

mod. ECM 1	53000052	185,00
mod. ECM 2	53000053	202,00
mod. ECM 3	53000054	223,00
mod. ECM 4	53000055	234,00
mod. ECM 5	53000056	269,00
mod. ECM 6	53000057	310,00
mod. ECM 7	53000058	332,00

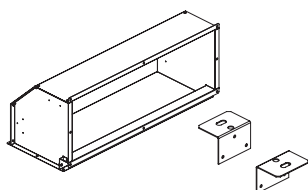

90° delivery plenum - insulated ceiling fixing kit included

mod. ECM 1	53000059	256,00
mod. ECM 2	53000060	269,00
mod. ECM 3	53000061	283,00
mod. ECM 4	53000062	296,00
mod. ECM 5	53000063	281,00
mod. ECM 6	53000064	367,00
mod. ECM 7	53000065	373,00

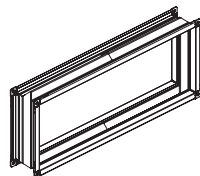

Anti-vibration joint suction and delivery

mod. ECM 1	53000066	251,00
mod. ECM 2	53000067	258,00
mod. ECM 3	53000068	282,00
mod. ECM 4	53000069	284,00
mod. ECM 5	53000070	313,00
mod. ECM 6	53000071	346,00
mod. ECM 7	53000072	365,00

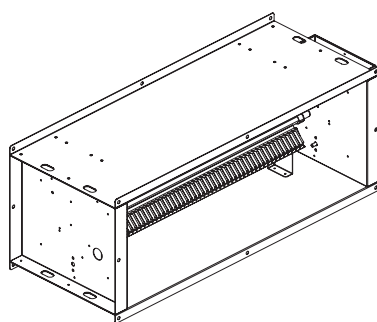

Heating section

Technical data:
with electrical resistance
(400Vca/3Ph+N/50-60Hz)

SRE 1-A	750 x 300 x (H)283 mm	4500W	53000073	1.010,00
SRE 1-B		6000W	53000074	1.010,00
SRE 2-A	1050 x 300 x (H)283 mm	7500W	53000075	1.058,00
SRE 2-B		9600W	53000076	1.058,00
SRE 3-A	1250 x 300 x (H)333 mm	7500W	53000077	1.069,00
SRE 3-B		9600W	53000078	1.069,00
SRE 4-A	1400 x 300 x (H)358 mm	9000W	53000079	1.085,00
SRE 4-B		12000W	53000080	1.085,00
SRE 5-A	1500 x 300 x (H)383 mm	9000W	53000081	1.090,00
SRE 5-B		12000W	53000082	1.090,00
SRE 6-A	2170 x 300 x (H)358 mm	15000W	53000083	1.512,00
SRE 6-B		19200W	53000084	1.512,00
SRE 7-A	2170 x 300 x (H)383 mm	15000W	53000085	1.552,00
SRE 7-B		19200W	53000086	1.552,00

MHD ECM

Reduced thickness ductable air treatment terminal units



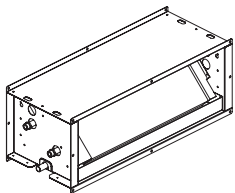
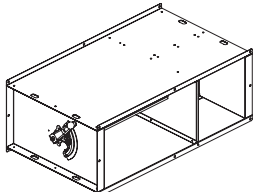
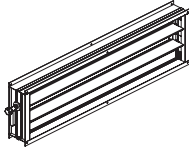
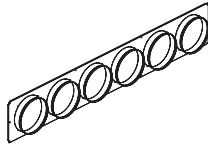
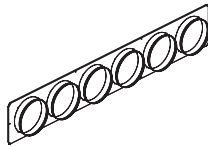
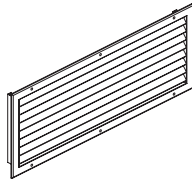

Accessories MHD ECM

		Code	€
	Section of post heating/cooling with water coil	mod. ECM 1	53000087 445,00
		mod. ECM 2	53000088 506,00
		mod. ECM 3	53000089 619,00
		mod. ECM 4	53000090 680,00
		mod. ECM 5	53000091 773,00
		mod. ECM 6	53000092 944,00
		mod. ECM 7	53000093 988,00
	Section with air intake (manual)	mod. ECM 1	53000094 440,00
		mod. ECM 2	53000095 467,00
		mod. ECM 3	53000096 492,00
		mod. ECM 4	53000097 506,00
		mod. ECM 5	53000098 529,00
		mod. ECM 6	53000099 638,00
		mod. ECM 7	53000100 643,00
	Aluminum shutter	mod. ECM 1	53000101 216,00
		mod. ECM 2	53000102 257,00
		mod. ECM 3	53000103 262,00
		mod. ECM 4	53000104 300,00
		mod. ECM 5	53000105 425,00
		mod. ECM 6	53000106 581,00
		mod. ECM 7	53000107 581,00
	Suction nozzle with circular connections	mod. ECM 1 n. 2 x 200	53000108 143,00
		mod. ECM 2 n. 3 x 200	53000109 163,00
		mod. ECM 3 n. 4 x 200	53000110 184,00
		mod. ECM 4 n. 3 x 300	53000111 192,00
		mod. ECM 5 n. 4 x 300	53000112 197,00
		mod. ECM 6 n. 6 x 300	53000113 253,00
		mod. ECM 7 n. 6 x 300	53000114 256,00
	Delivery union with circular connections	mod. ECM 1 n. 2 x 200	53000115 157,00
		mod. ECM 2 n. 3 x 200	53000116 180,00
		mod. ECM 3 n. 4 x 200	53000117 203,00
		mod. ECM 4 n. 3 x 300	53000118 209,00
		mod. ECM 5 n. 4 x 300	53000119 223,00
		mod. ECM 6 n. 6 x 300	53000120 262,00
		mod. ECM 7 n. 6 x 300	53000121 266,00
	Fixed intake grille with mandatory filter	mod. ECM 1	53000122 182,00
		mod. ECM 2	53000123 196,00
		mod. ECM 3	53000124 257,00
		mod. ECM 4	53000125 281,00
		mod. ECM 5	53000126 358,00
		mod. ECM 6	53000127 574,00
		mod. ECM 7	53000128 586,00

MHD ECM

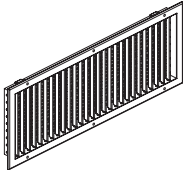
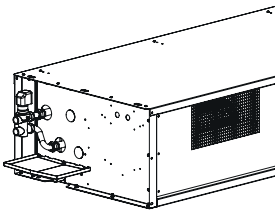
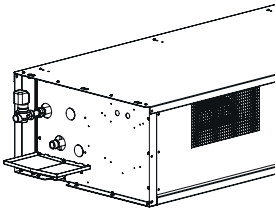
Reduced thickness ductable air treatment terminal units

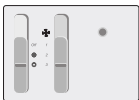
Accessories MHD ECM

		Code	€
	Adjustable delivery grille	mod. ECM 1	53000129 172,00
		mod. ECM 2	53000130 182,00
		mod. ECM 3	53000131 284,00
		mod. ECM 4	53000132 326,00
		mod. ECM 5	53000133 346,00
		mod. ECM 6	53000134 395,00
		mod. ECM 7	53000135 402,00
	3-way by pass valve kit with servo control	mod. ECM 1	53000136 178,00
		mod. ECM 2	53000137 188,00
		mod. ECM 3	53000138 215,00
		mod. ECM 4	53000139 257,00
		mod. ECM 5	53000140 257,00
		mod. ECM 6	53000141 1.045,00
		mod. ECM 7	53000142 1.262,00
	2-way by pass valve kit with servo control	mod. ECM 1	53000143 137,00
		mod. ECM 2	53000144 142,00
		mod. ECM 3	53000145 167,00
		mod. ECM 4	53000146 170,00
		mod. ECM 5	53000147 170,00
		mod. ECM 6	53000148 894,00
		mod. ECM 7	53000149 1.030,00
	LCD Thermostat	53000150	258,00
	Thermostat Cover	53000151	40,00
	Mechanical consensus thermostat for wall-mounted electronic room thermostat or basic control	50005205	36,00
	Basic wall control for managing the 3 speeds and for winter/summer selection	36205212	52,00
	Wall-mounted electronic room thermostat with summer-off-winter selector and 3-speed switch	50005230	82,00

Dimensions MHD ECM

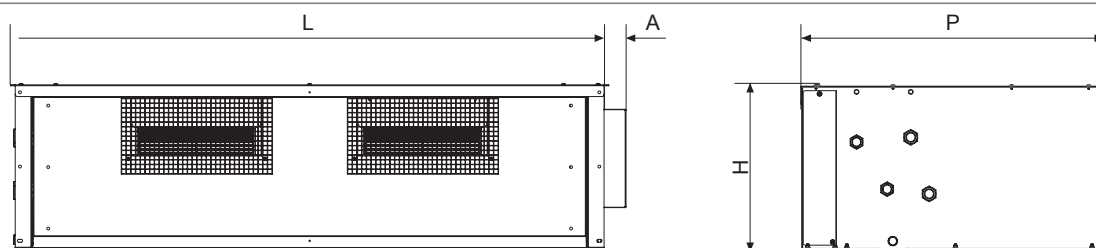

Mod. MHD ECM		U.M.	ECM 1	ECM 2	ECM 3	ECM 4	ECM 5	ECM 6	ECM 7
Length	L	mm	770	1070	1270	1420	1520	2190	2190
Height	H	mm	297	297	347	372	397	373	398
Depth	P	mm	643	643	643	770	770	770	770
			38	38	38	38	38	38	38
Motors - fans		n.	1-1	1-2	1-2	1-2	1-2	2-4	2-4

MHD ECM

Reduced thickness ductable air treatment terminal units

Technical data table MHD ECM

DESCRIPTION	U.M.		ECM 1	ECM 2	ECM 3	ECM 4	ECM 5	ECM 6	ECM 7
Cooling Total Power	W	6	3058	-	-	-	-	-	-
	W	5	2987	6358	9708	12565	-	26062	-
	W	4	2856	6058	9016	12010	16014	24480	29589
	W	3	2785	5924	7825	11274	15131	22568	27851
	W	2	2581	5618	6966	9140	13359	21797	24818
	W	1	2433	5193	5689	6630	11810	13261	22020
Cooling Sensible Power	W	6	2312	-	-	-	-	-	-
	W	5	2256	4618	7048	9145	-	19562	-
	W	4	2147	4388	6506	8720	11784	18260	22249
	W	3	2092	4284	5585	8144	11081	16668	20801
	W	2	1926	4048	4926	6490	9649	13039	18308
Water Flow	l/h	6	545	-	-	-	-	-	-
	l/h	5	530	1122	1714	2236	-	4646	-
	l/h	4	506	1065	1590	2127	2859	4348	5298
	l/h	3	493	1041	1380	1994	2965	4003	4976
	l/h	2	457	988	1229	1614	2373	3182	4430
Water Side pressure Drops	kPa	6	11,4	-	-	-	-	-	-
	kPa	5	10,8	16,0	20,8	22,0	-	23,7	-
	kPa	4	9,9	14,6	18,6	20,2	22,8	21,1	32,0
	kPa	3	9,2	14,1	14,5	18,0	21,0	18,2	28,09
	kPa	2	8,3	12,8	11,8	12,4	16,8	12,1	22,8
Heating Power	W	6	3230	-	-	-	-	-	-
	W	5	3170	6950	10510	13880	-	30200	-
	W	4	3020	6570	9630	13140	1798	28020	34170
	W	3	2900	6410	8310	12240	1684	25540	31820
	W	2	2710	6050	7350	9740	14640	1984	27930
	W	1	2520	5570	5880	6880	1284	14310	24450
Water Flow	l/h	6	562	-	-	-	-	-	-
	l/h	5	547	1211	1830	2419	-	5261	-
	l/h	4	519	1144	1686	2289	3132	4881	5952
	l/h	3	506	1116	1447	2131	2934	4449	5544
	l/h	2	470	1054	1280	1696	2550	3454	4865
Water Side pressure Drops	kPa	6	10,1	-	-	-	-	-	-
	kPa	5	9,9	15,2	19,8	20,8	-	24,3	-
	kPa	4	9,0	13,8	17,0	18,9	22,6	21,3	32,4
	kPa	3	8,4	13,2	13,1	17,0	20,2	18,1	28,6
	kPa	2	7,0	11,9	10,5	11,1	15,8	11,6	22,7
Heating Power	W	6	3860	-	-	-	-	-	-
	W	5	3760	8280	12530	16540	-	35740	-
	W	4	3570	7830	11560	15660	21370	33210	40470
	W	3	3480	7640	9930	14600	20030	30310	37740
	W	2	3240	7220	8790	11640	17440	23620	33190
	W	1	3030	6650	7050	8260	15330	17090	29110



- Allowable voltage values: ~230V / 1ph / 50-60Hz
- Wired speeds

MHD ECM

Reduced thickness ductable air treatment terminal units

Technical data table MHD ECM

DESCRIPTION	U.M.		ECM 1	ECM 2	ECM 3	ECM 4	ECM 5	ECM 6	ECM 7
Water Flow	l/h	6	545	-	-	-	-	-	-
	l/h	5	530	1122	1714	2236	-	4646	-
	l/h	4	506	1065	1590	2127	2859	4348	5928
	l/h	3	493	1041	1380	1994	2695	4003	4976
	l/h	2	457	988	1229	1614	2373	3182	4430
	l/h	1	431	914	1003	1171	2103	2344	3931
Water Side pressure Drops	kPa	6	9,4	-	-	-	-	-	-
	kPa	5	9,2	13,1	17,3	17,9	-	19,3	-
	kPa	4	8,3	11,9	15,2	16,4	18,9	17,1	25,9
	kPa	3	7,9	11,5	11,8	14,6	17,1	14,8	23,2
	kPa	2	6,7	10,4	9,6	10,1	13,6	9,9	18,9
	kPa	1	6,2	9,1	6,7	5,7	11,0	5,8	15,3
Air Flow	m ³ /h	6	534	-	-	-	-	-	-
	m ³ /h	5	526	1114	1693	2240	-	5429	-
	m ³ /h	4	484	1039	1528	2128	3052	4916	6232
	m ³ /h	3	469	1007	1267	1946	2805	4357	5668
	m ³ /h	2	382	938	1092	1470	2350	3161	4776
	m ³ /h	1	353	848	838	976	1997	2122	4027
Static Pressure	Pa	6	61	-	-	-	-	-	-
	Pa	5	57	63	90	117	-	77	-
	Pa	4	50	55	73	106	86	63	86
	Pa	3	46	50	50	88	72	50	72
	Pa	2	39	44	37	50	50	26	50
	Pa	1	33	36	22	22	37	11	37
SUCTION + radiated sound power level	dB(A)	6	63	-	-	-	-	-	-
	dB(A)	5	62	71	65	70	-	73	-
	dB(A)	4	60	68	63	68	73	72	76
	dB(A)	3	59	67	59	64	70	69	74
	dB(A)	2	56	67	55	58	67	61	70
	dB(A)	1	54	63	51	55	63	55	66
Sound power level	dB(A)	6	62	-	-	-	-	-	-
	dB(A)	5	61	67	69	74	-	76	-
	dB(A)	4	59	65	66	70	75	74	78
	dB(A)	3	58	64	60	65	71	70	75
	dB(A)	2	55	64	57	59	66	61	69
	dB(A)	1	52	60	50	56	62	55	65
Absorbed power from the Fan Motor	W	6	75	-	-	-	-	-	-
	W	5	69	131	207	343	-	829	-
	W	4	58	109	156	305	490	632	1043
	W	3	53	99	95	240	379	458	790
	W	2	35	82	66	115	232	203	478
	W	1	29	64	37	45	158	87	309
Current Absorbed from the Fan Motor	A	6	0,65	-	-	-	-	-	-
	A	5	0,61	1,02	1,78	1,56	-	3,70	-
	A	4	0,71	0,84	1,16	1,37	2,59	2,85	5,57
	A	3	0,43	0,77	0,67	1,10	1,93	2,13	4,04
	A	2	0,26	0,66	0,48	0,63	1,05	1,17	2,16
	A	1	0,24	0,48	0,28	0,40	0,68	0,80	1,34
Supply voltage			230V/1/50Hz						
Net weight	Kg		25	40	51	65	76	133	141
Gross weight	Kg		31	42	53	67	78	133	141



- The test for detecting the sound power level was carried out in accordance with the EN 16583:2015 standard
 - Sound pressure level: considered 8.6 dB(A) lower than the sound power in a 90 m3 room with a reverberation time of 0.5 sec.